

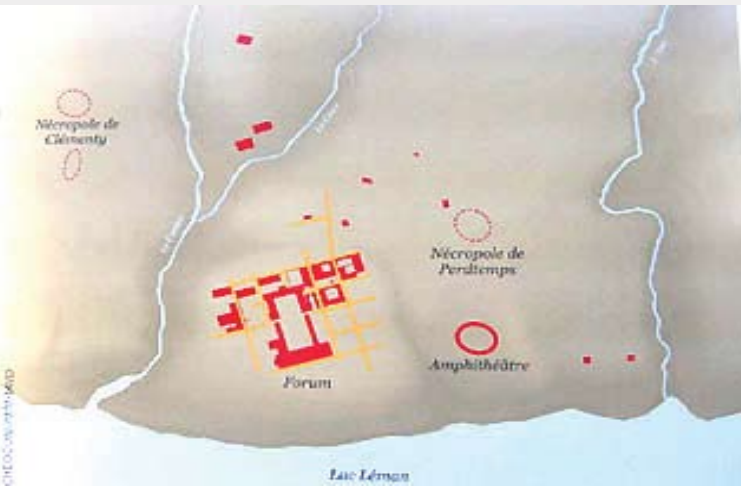

RACINES





AUGUST 2009
 | RACINES
 | PERDTEMPS
 NYON
 SWITZERLAND

TRANSPARENCE
 TRANSLUCENCE
 NECROPOLE
 ORIENTATION
 VEIL
 ROOTS

TREES
 ROOTS
 MEMORY
 LIGHT

| DEFINITIONS



| PLACE

RACINES will occupy the main public parking space (309 parking places) of the City of Nyon, Switzerland.

| DATES

Project is planned for August 2009.



RAGINE | ROOT¹

Ce mot est issu du bas latin *radicina* (cf. roum. *rădăcina*), du classique *radix*, *radicis* « racine » et « source, origine » (cf. it. *radice*, occ. *raiç*, cat. *arrel*, esp. et port. *raiz*, all. *Rettich* « radis »), apparenté à *ramus* « branche » (→ 1. ramage, 2. rame, rameau, 1. ramée, 2. ramer, rameux, ramier, se ramifier, ramille, ramoner, ramure, rinceau), à l'anglais *root* (→ arrow-root) et au grec *rhiza* « racine » (→ rhizo-, rhizome). La famille latine a donné *arracher* et *éradication*, *radical* (« de la racine » d'où « fondamental »), des termes de botanique comme *radicule*, *radicelle* et *radicant*. La famille comprend des noms de légumes comme *radis* (de l'it.) Le français a produit *enraciner* et *déraciner*, *raciner* et *racinage*, ainsi que *racinal* « pièce de charpente ». *Rachis* n'appartient pas à cette famille étymologique. L'allemand a emprunté *Radieschen* « radis rose » et *radikal*, le néerlandais, *radijs*.

| HOW TO PLAY

| SIGN IN

| TEAM

| TASKS

| RESOURCES

| COMPETENCES

| ADVANCEMENT

| DESCRIPTION

| SCENARIO

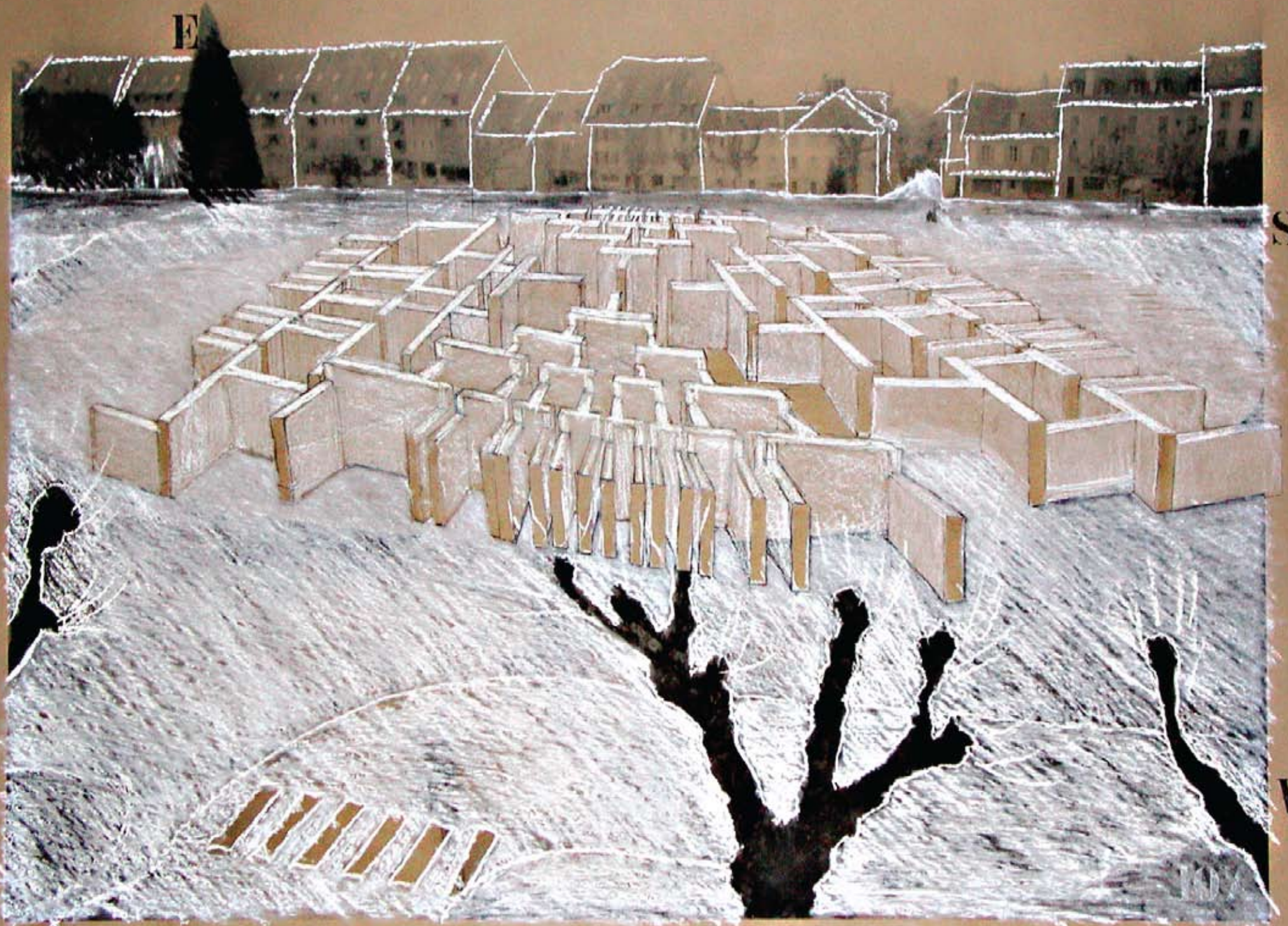



AUGUST 2009
 | RACINES
 | PERDTEMPS
 NYON
 SWITZERLAND

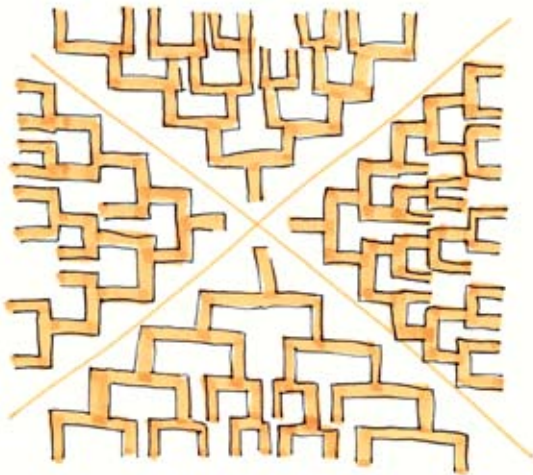

| DESCRIPTION

Hollow scaffolding walls covered with white translucent veil spread like roots into the four directions. Light casts shadows of movements as people walk through or within the passways just wide enough to invite their presence.

Place Perdtemps | roman time = a necropole.

Perdtemps | the origin of the name is to be researched
 Surrounded by trees | branches and roots.

Parking | traces and partitions, rythms and movements.

Roots | origins, memories ... is the nature of labyrinth of the journey or of the walls we erect in our wanderings.

Light | forseing a way through these ephemeral walls.

| DIMENSIONS

This project is drawn into a 60 meters wide circle. Heights range from 2 meters on the edges to 4 meters in the center. Walls are 1 meter wide.

| SCENARIO

Visitors will walk like through the drying sheets on the clothesline of their memories. Will movements and sound and shadows not wake their senses as the sun lights the translucent fabric. Curious to discover what they perceive but do not see, they will wonder within the walls and contribute to further movements and impressions by their presence.

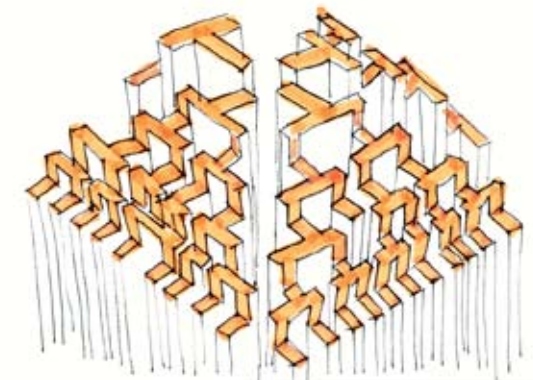

TRANSPARENCE
 TRANSLUCENCE
 NECROPOLE
 ORIENTATION
 VEIL
 ROOTS

TREES
 ROOTS
 MEMORY
 LIGHT

| DEFINITIONS

| HOW TO PLAY
 | SIGN IN
 | TEAM
 | TASKS
 | RESOURCES
 | COMPETENCES
 | ADVANCEMENT
 | DESCRIPTION
 | SCENARIO

0.8
100

3.48
3.10
2.73
2.35

Y
0
30
25
20
15
10
5
0
5
10
15
20
25
30

METRES

X

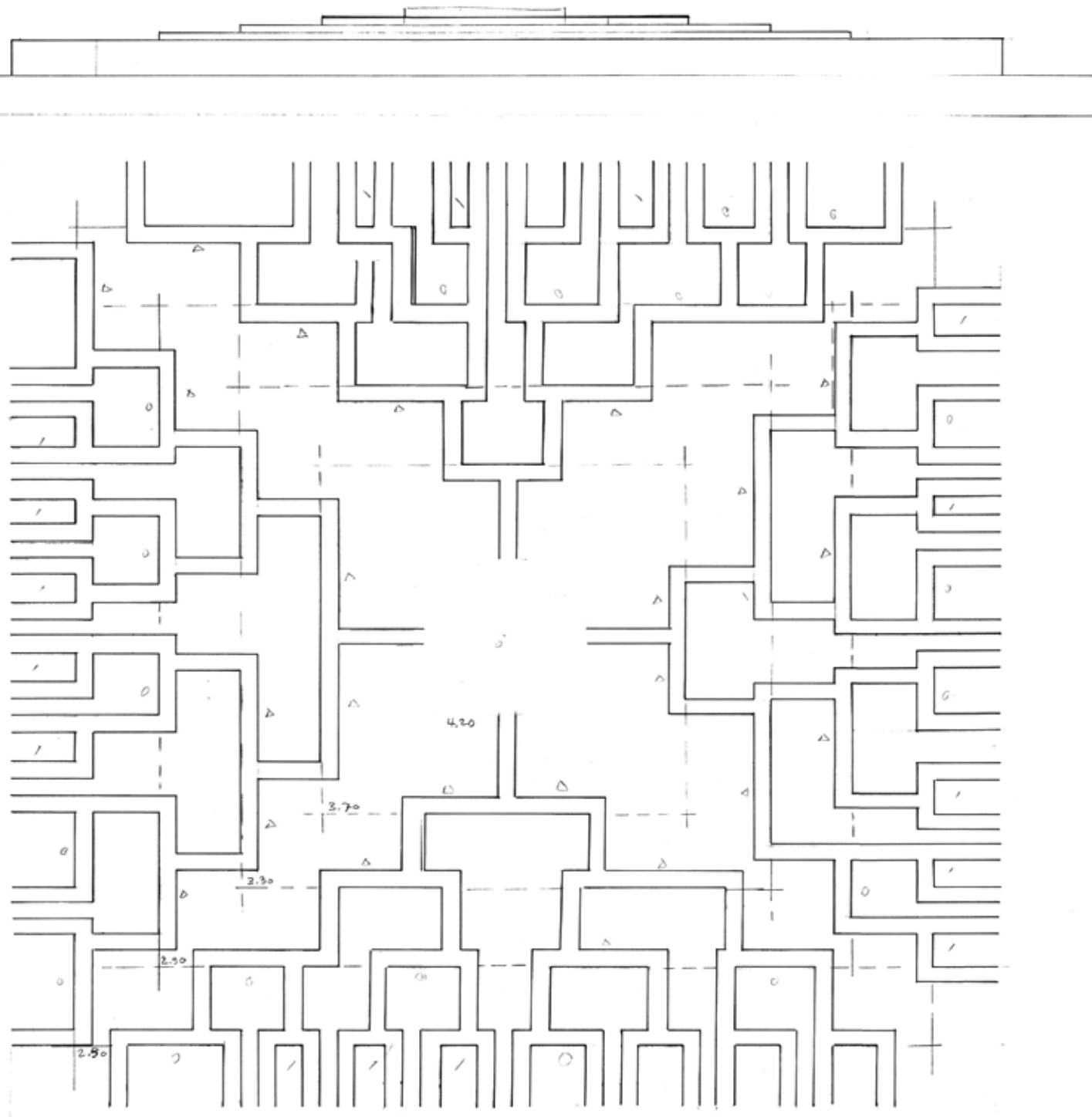



AUGUST 2009
| RACINES
| PERDTEMPS
NYON
SWITZERLAND

TRANSPARENCE
TRANSLUCENCE
NECROPOLE
ORIENTATION
VEIL
ROOTS

TREES
ROOTS
MEMORY
LIGHT

| DEFINITIONS

| HOW TO PLAY
| SIGN IN
| TEAM
| TASKS

| RESOURCES
| COMPETENCES
| ADVANCEMENT
| DESCRIPTION
| SCENARIO



| AVANCEMENT

The City of Nyon has given authorization to build the temporary installation RACINES on the Place Perdtemps in August 2009. Precise dates to follow shortly.

| COMPETENCES

- sewing
- scaffolding construction [bamboo]
- to blaze bamboo poles

illustration [mouse-on to see details & % of this task]

| TASK

create a descriptive brochure of the overall project

| 80 hrs

| SIGN IN

photography

film

| TEAM

| team members RACINES 2007-2008



Albert (for participation details, follow the link)

Elisabeth, Jean-François, la ville de Nyon, Jean-Christophe, Sigrid,
Dominique, Monique, etc ...



HELLO | LOGIN | LOGOUT

HOME | PROJECTS

PLACES

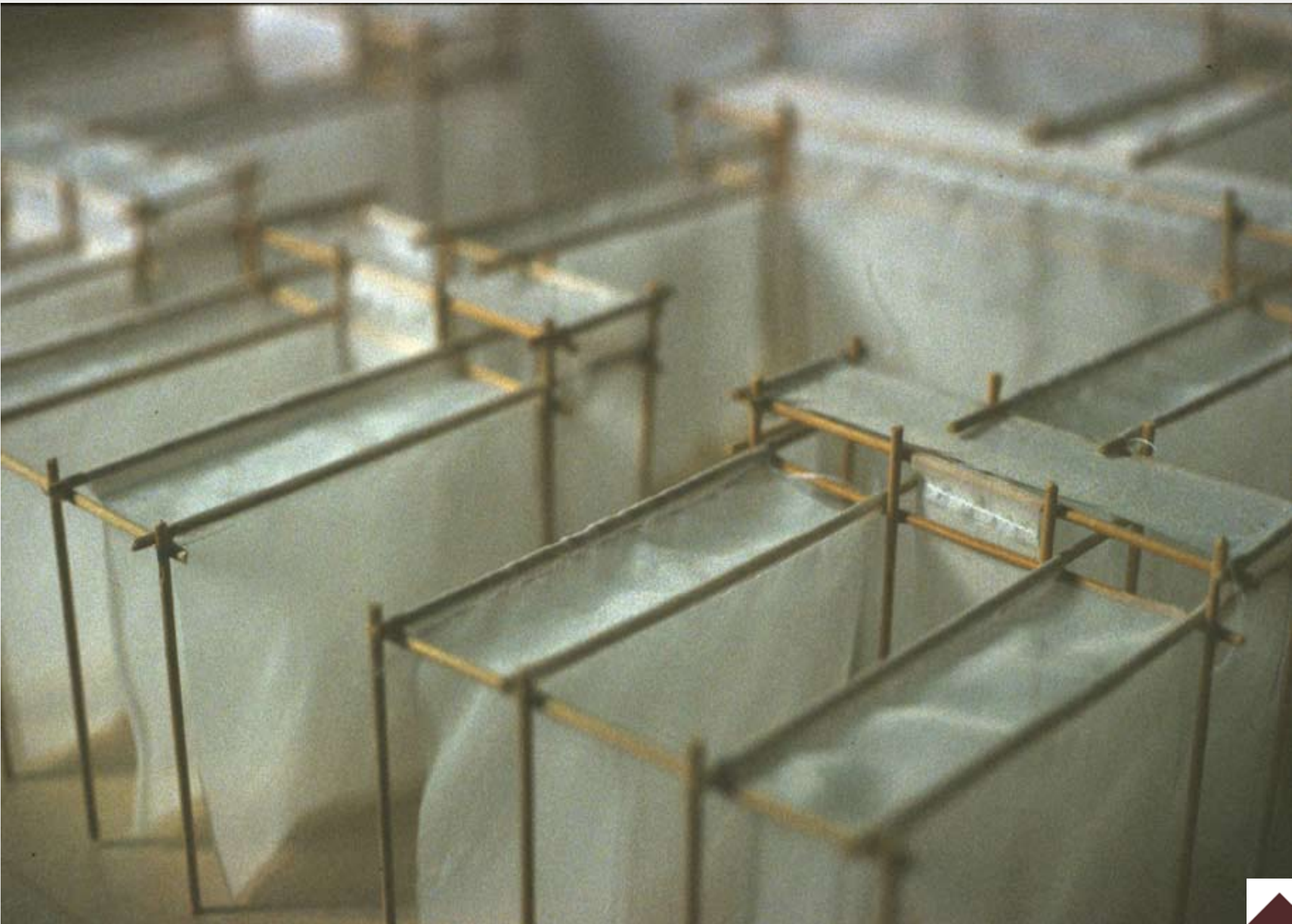



AUGUST 2009
 | RACINES
 | PERDTEMPS
 NYON
 SWITZERLAND

TRANSPARENCE
 TRANSLUCENCE
 NECROPOLE
 ORIENTATION
 VEIL
 ROOTS

 TREES
 ROOTS
 MEMORY
 LIGHT
 | DEFINITIONS



MATERIAL RESOURCES

| estimation

traditional bamboo scaffolding

- | quantity 1'800 poles
- | quality bamboo
- | size 6 & 8 cm X 500 cm

joints [traditional rope ties]

- | quantity 6'000 meters
- | quality rafia or plastic

anchorage points

- | quantity 16 pieces
- | quality metal



fabric [mouse-on to see % completed]

- | quantity 6'000 m²
ou 2'000 meters x 3 meters wide
- | quality SPI or nylon parachute white translucide fabric

| HOW TO PLAY
 | SIGN IN
 | TEAM
 | TASKS
 | PEOPLE
 | COMPETENCES
 | ADVANCEMENT
 | DESCRIPTION
 | SCENARIO

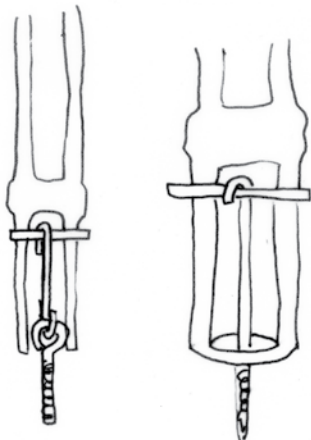



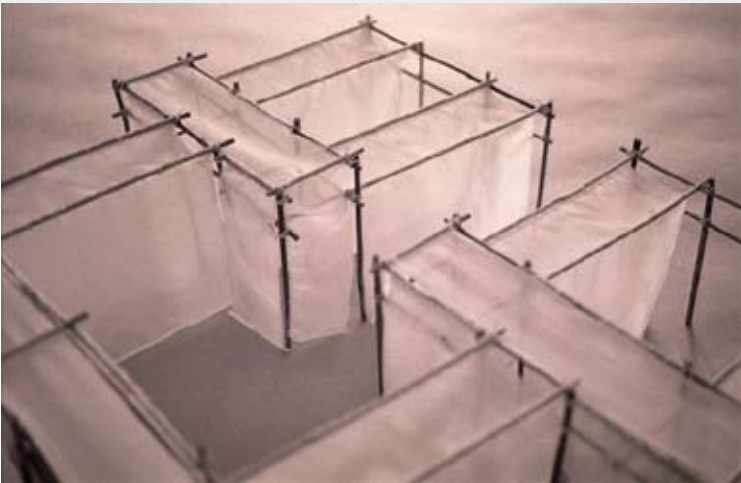

AUGUST 2009
 | RACINES
 | PERDTEMPS
 NYON
 SWITZERLAND

TRANSPARENCE
 TRANSLUCENCE
 NECROPOLE
 ORIENTATION
 VEIL
 ROOTS
 TREES
 ROOTS
 MEMORY
 LIGHT
 | DEFINITIONS



| MEDIA PRE-PRODUCTION

drawings, collages

- 1 | dimension 160 cm X 230 cm
 | media collage sulfurized paper | tissue paper | chalk | thread
- 4 | dimension 60 cm X 100 cm
 | media photo | chalk

scale models

- 10 | dimension 150 cm X 150 cm X 20 cm
 | media wood | parachute nylon | thread
- 11 | dimension 72 cm X 82 cm X 26 cm
 | media bamboo | parachute nylon | string

photographies

- | camera nikon and nikkormat
- | media negative et diapositive 35 mm

sketches

- | dimension various sizes
- | media felt pen | chalk | charcoal

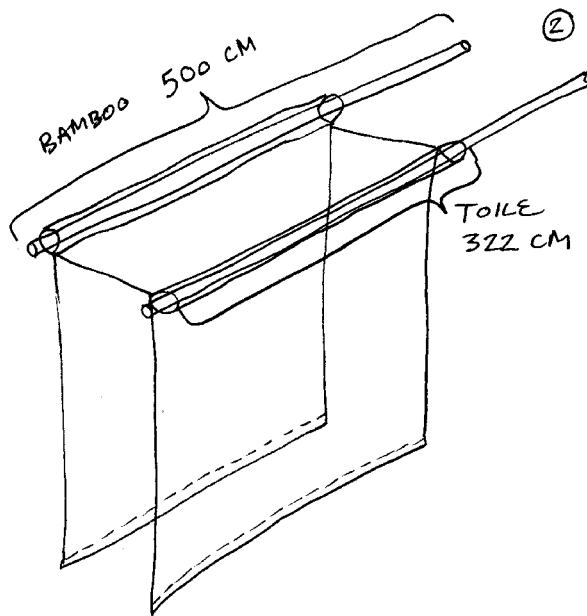

| HOW TO PLAY
 | SIGN IN
 | TEAM
 | TASKS
 | PEOPLE
 | COMPETENCES
 | ADVANCEMENT
 | DESCRIPTION
 | SCENARIO

ART IN SOCIAL CONTEXT | ASC
contact@artinsocialcontext.ch
www.artinsocialcontext.ch
+41 (0)22 566 76 46
+41 (0)78 659 72 65
2007 Copyright

